

Exam 2 Review

Lecture 10



Format

- 3 problems, with multiple sub-parts
- No notes, calculators, books, computers, phones, etc. may be used



Content

Database design, including...

- ER Diagrams
- Mapping ER Diagrams to Relations
- Normalization



ER Diagrams & Mapping

- Conceptual design: goals, approaches
- All the notation we covered
 - Entities: weak/strong
 - Attributes: composite, multi-valued, derived, keys
 - Relationships: cardinality, structural, attributes
 - Specialization/Generalization
 - When to use!
- Mapping to tables
 - Multiple methods for specialization/generalization



Exercise

- Describe in words the following ERD
 - How can you identify an instance of E ?
- Map E to relation(s)
 - What are the primary key(s)?
 - What happens to other key(s)?

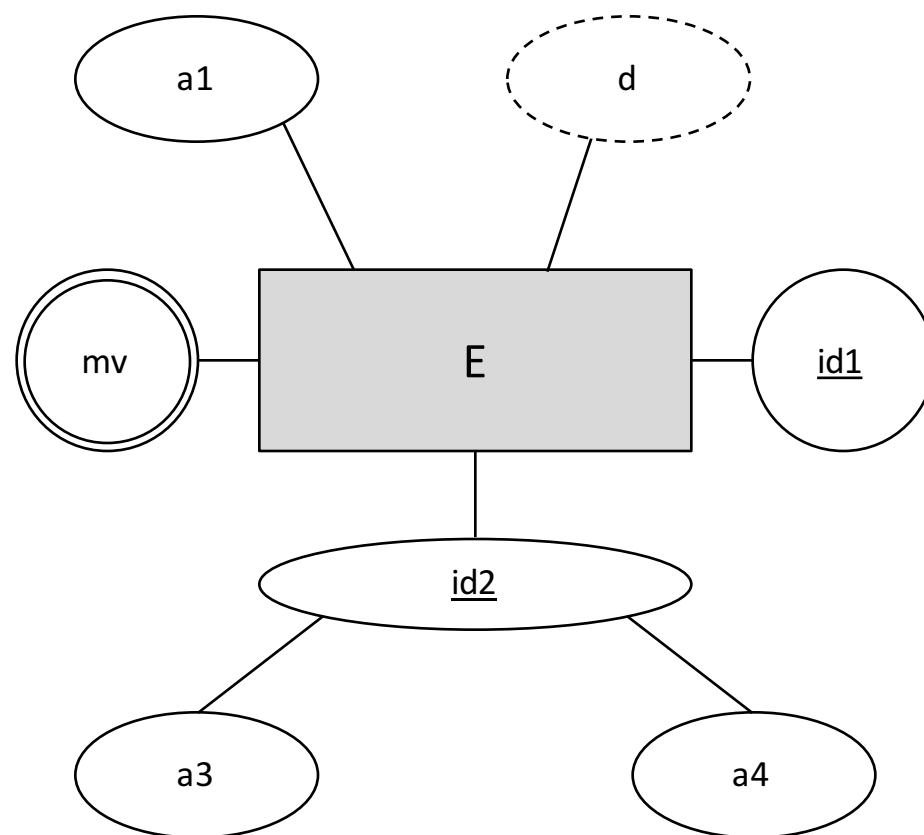

Answer

- All E's have an a1, an id1, an id2 composed of a3 and a4, and some number of mv's. By combining these you can determine the E's d.
- An E can be uniquely identified by either its id1, or the combination of a3 and a4.

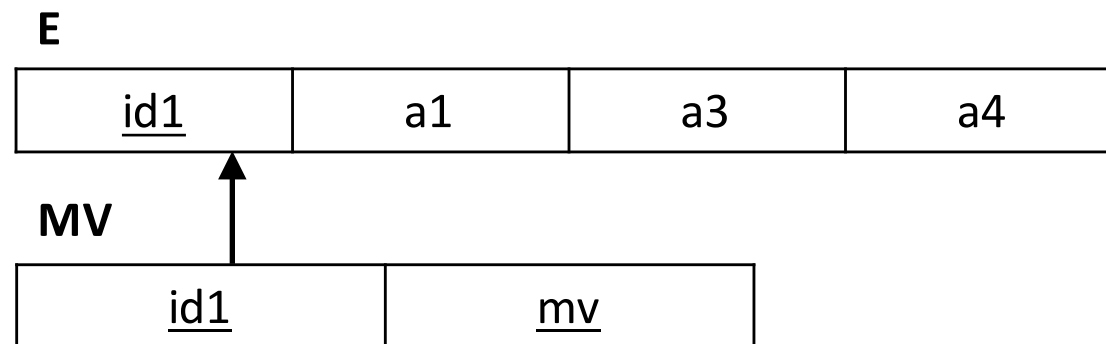

Exercise

Produce an ERD & corresponding relational schema

- An **S** has an **sa** and can be uniquely identified by its **sid**
- Each **S** must **R2** with a single **O2**, whereas each **O2** may **R2** with any number of **S**'s. When an **S** **R2**'s an **O2**, it is important to note the corresponding **RA2**
- An **O2** has an **x** and can be uniquely identified by its **o2_id**, which is comprised of **p1** and **p2**
- A **W** is identified by its corresponding **S**, in combination with its own **wid**, consisting of a **wa** and **wb**
- Each **W** can **R1** with any number of **O1**'s, and likewise each **O1** can **R1** with any number of **W**'s. Each **R1** interaction has a corresponding **ra1**
- An **O1** is uniquely identified by its **o1_id** and also has an **x**



Answer (1)

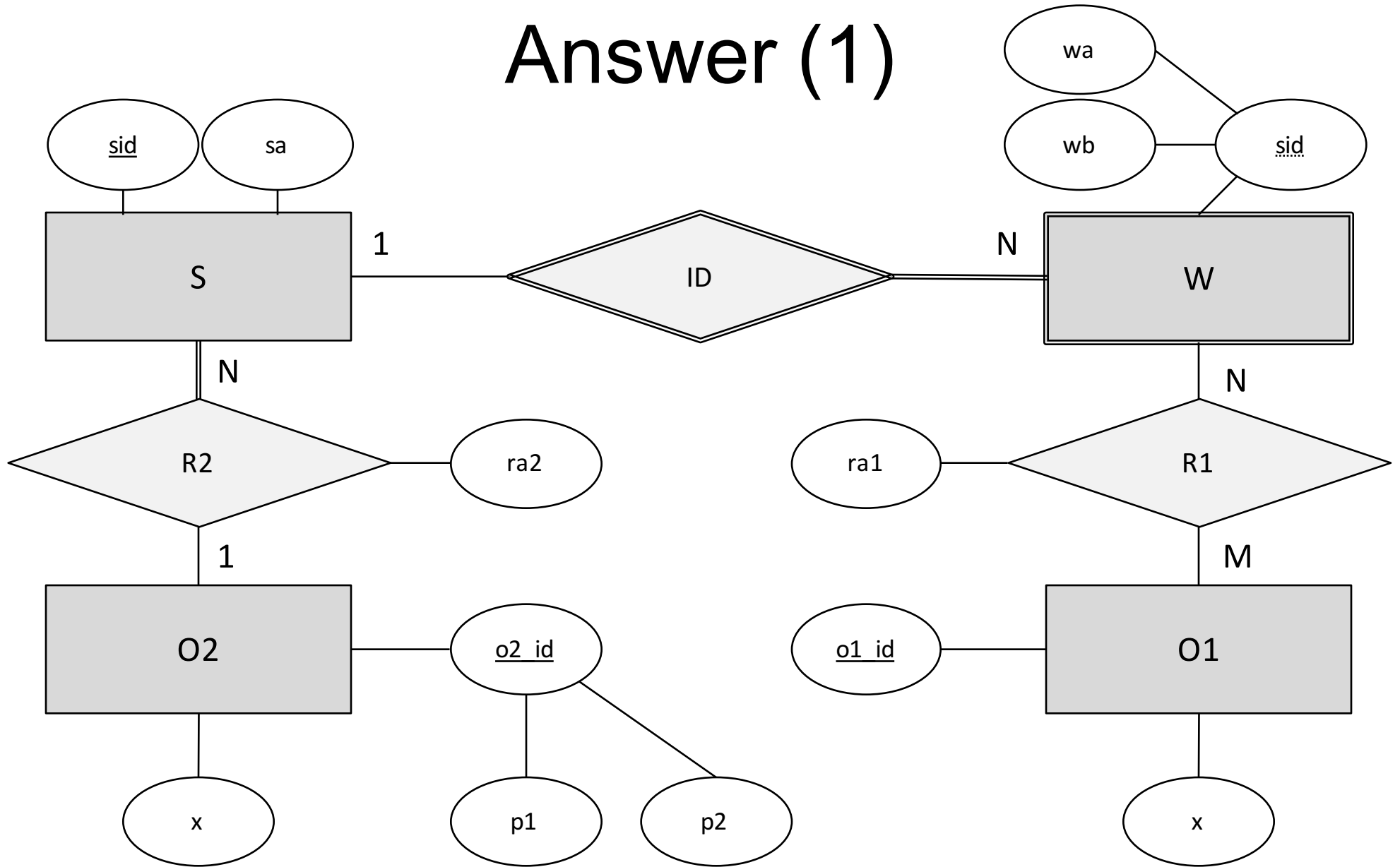

Answer (2)

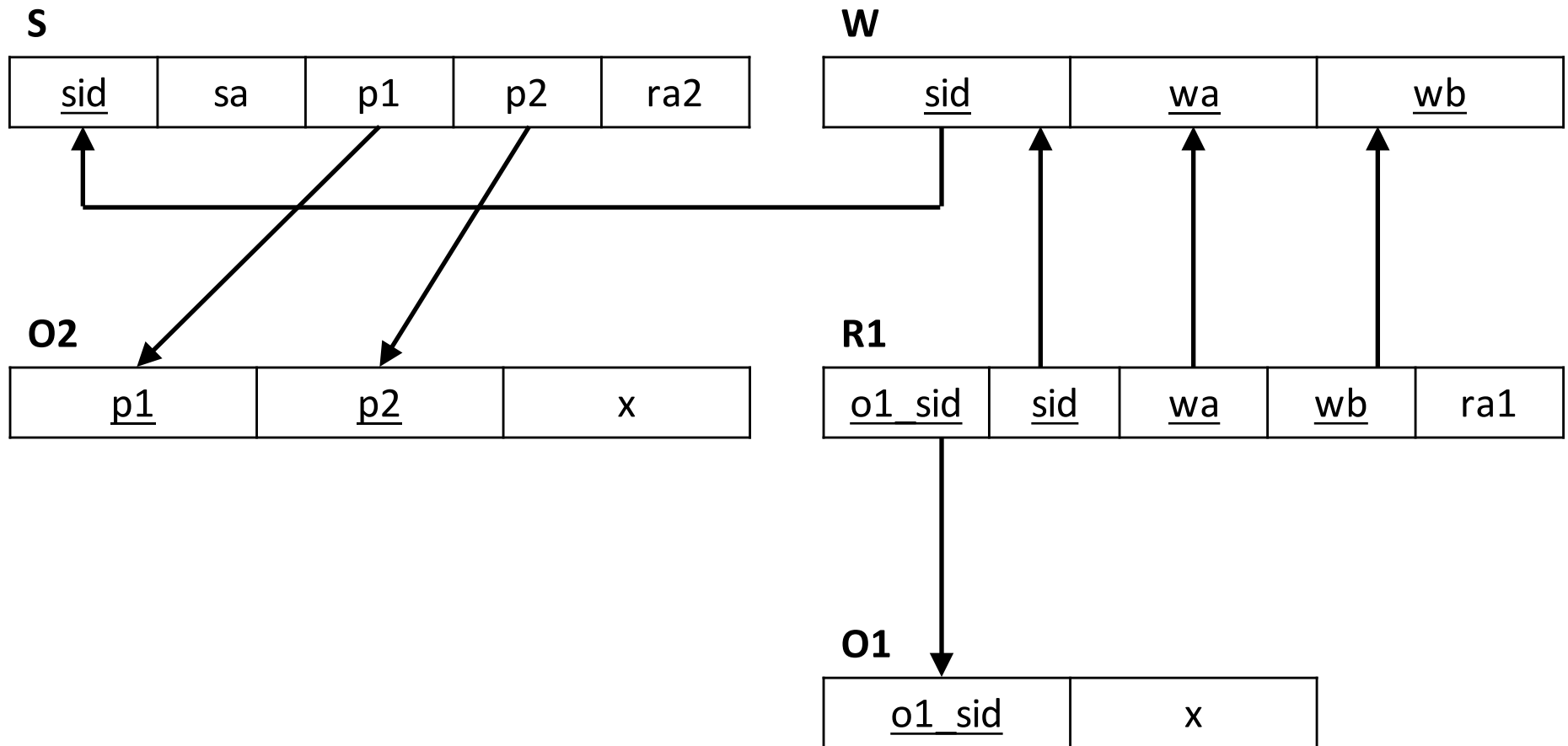

Exercise

Map this ERD to relations in **two** different ways. Pros and cons of each?

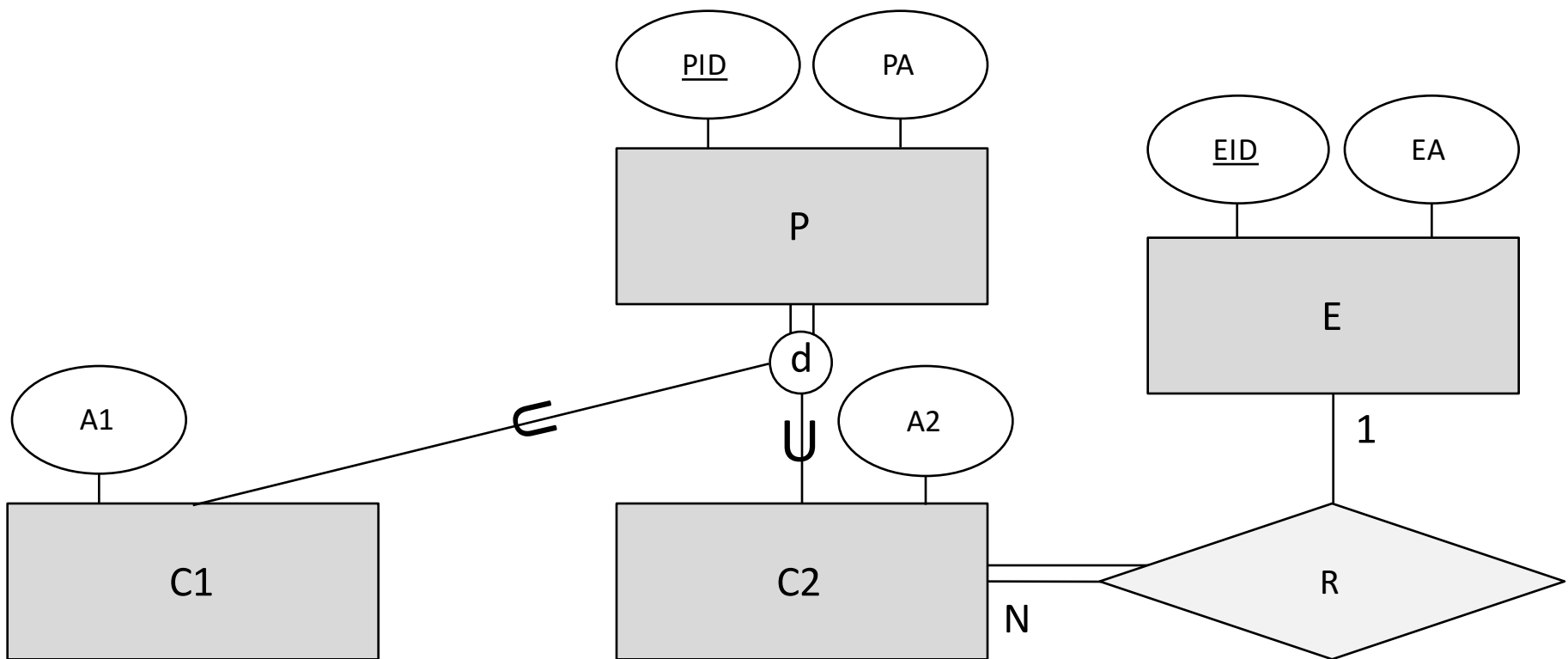

Answer

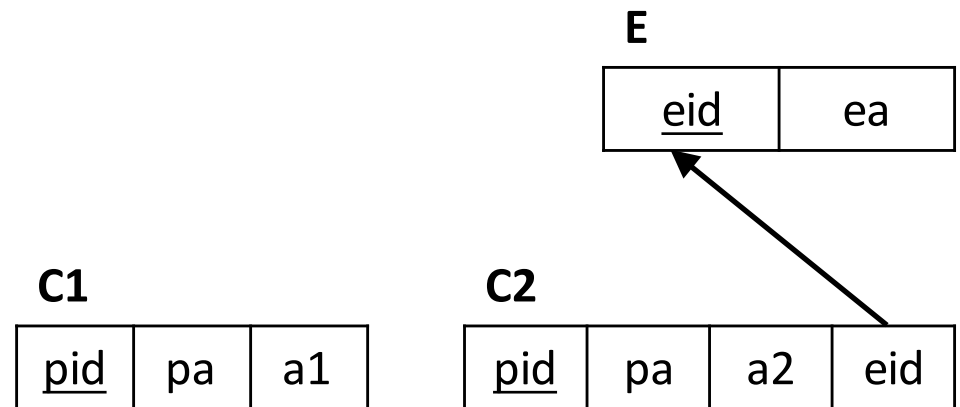
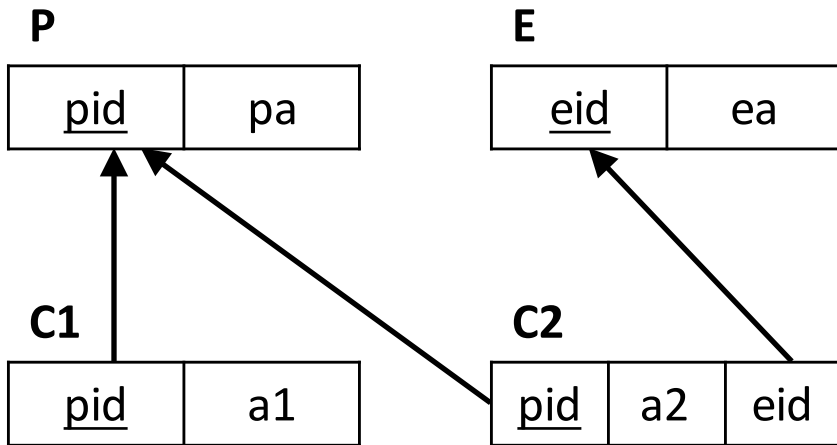

Normalization

- What are the goals of normalization?
 - Spurious tuples? Additive decomposition?
 - Modification anomalies? Examples!
- Functional dependencies
 - Definition, relationship to keys
 - Trivial, transitive, full
- Normal forms
 - What do 1NF/2NF/3NF require?
 - Decomposition algorithm



Exercise

Non-Trivial FDs

$$TU \rightarrow W$$

$$VW \rightarrow S$$

$$S \rightarrow T$$

Key(s)

UVS

UVW

UVT

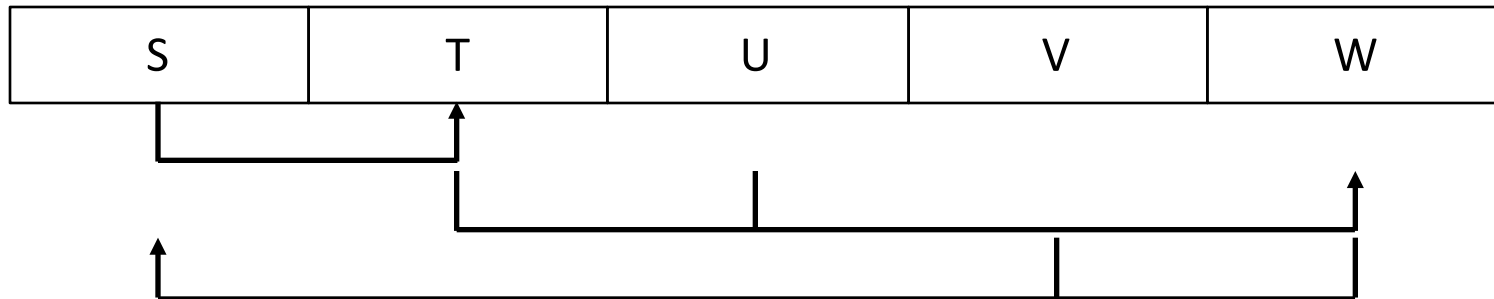

Exercise

Which NF? Why? Decompose to 3NF.

Foo

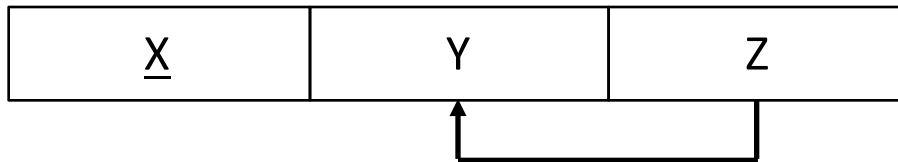

Bar

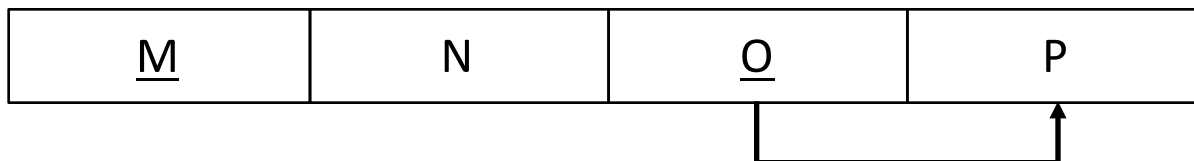

Answer

- Foo is in 2NF
 - 1NF (single PK attr)
 - Y is tFD on PK
 - Post: single PK/np

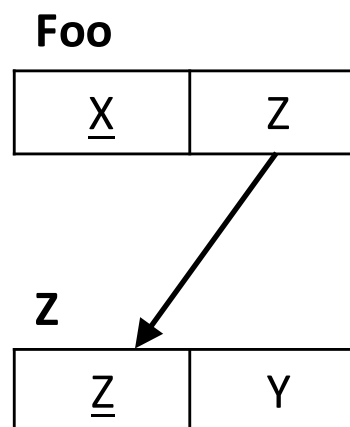

- Bar is in 1NF
 - P is not fFD on PK
 - Post:
 - Bar: N fFD on PK, single PK/np
 - O: single PK/np

